

# **SINGER**

## **9410**

31266452

# LIST OF PARTS

*Sewing Machine Model*

9410

by **SINGER**\*



A Publication of Product Support  
International Group Engineering

Printed in Taiwan

From the library of: Diamond Needle Corp

## INDEX

PAGE NO.	SUBASSEMBLY
1, 2	ATTACHMENT SET
3, 4	COVERS AND ADD ONS
5, 8	ARM TOP COVER
9, 10	ARM SHAFT DRIVE SYSTEM
11, 12	HAND WHEEL
13, 14	COAXIAL PRESSER BAR SYSTEM
15, 16	NEEDLE BAR & THREAD TAKE-UP
17, 22	ALPHA FEED
23, 24	HOOK SYSTEM (APOLLO)
25, 26	HOOK AND BOBBIN WINDING SYSTEM (CENTAUR)
27, 32	PATTERN, STITCH LENGTH CONTROL & CAM CONTROLLED FEED
33, 34	DEMAND RESPONSIVE NEEDLE TENSION SYSTEM
35, 38	ELECTRICAL EQUIPMENT

ATTACHMENT SET  
MODEL:9410

REF. NO.	PART NO.	DESCRIPTION
1	313030	ATTACHMENT COMPLETE
2	402673-455	ACCESSORY BOX COMPLETE (ALT:402673-454)
5	172336	BOBBIN
7	353364	NEEDLE PACK (ALT: 384064)
9	546358	LINT BRUSH
13	313992-451	PRESSER FOOT PLATE (SNAP-ON) FOR SEWING BUTTONHOLES
15	171480	PRESSER FOOT PLATE (SNAP-ON) FOR CORDING & SLIDE FASTENERS COMPL.
17	171463	SPECIAL PURPOSE PRESSER FOOT PLATE (SNAP-ON)
20	421588	FINGER GUARD ATTACHED TO PRESSER BAR FOR ITALY AND U.S. SCHOOL MACHINES. IN ACCESSORY BOX FOR FRANC
21	171110	BLINDSTITCH GUIDE

# ATTACHMENT SET

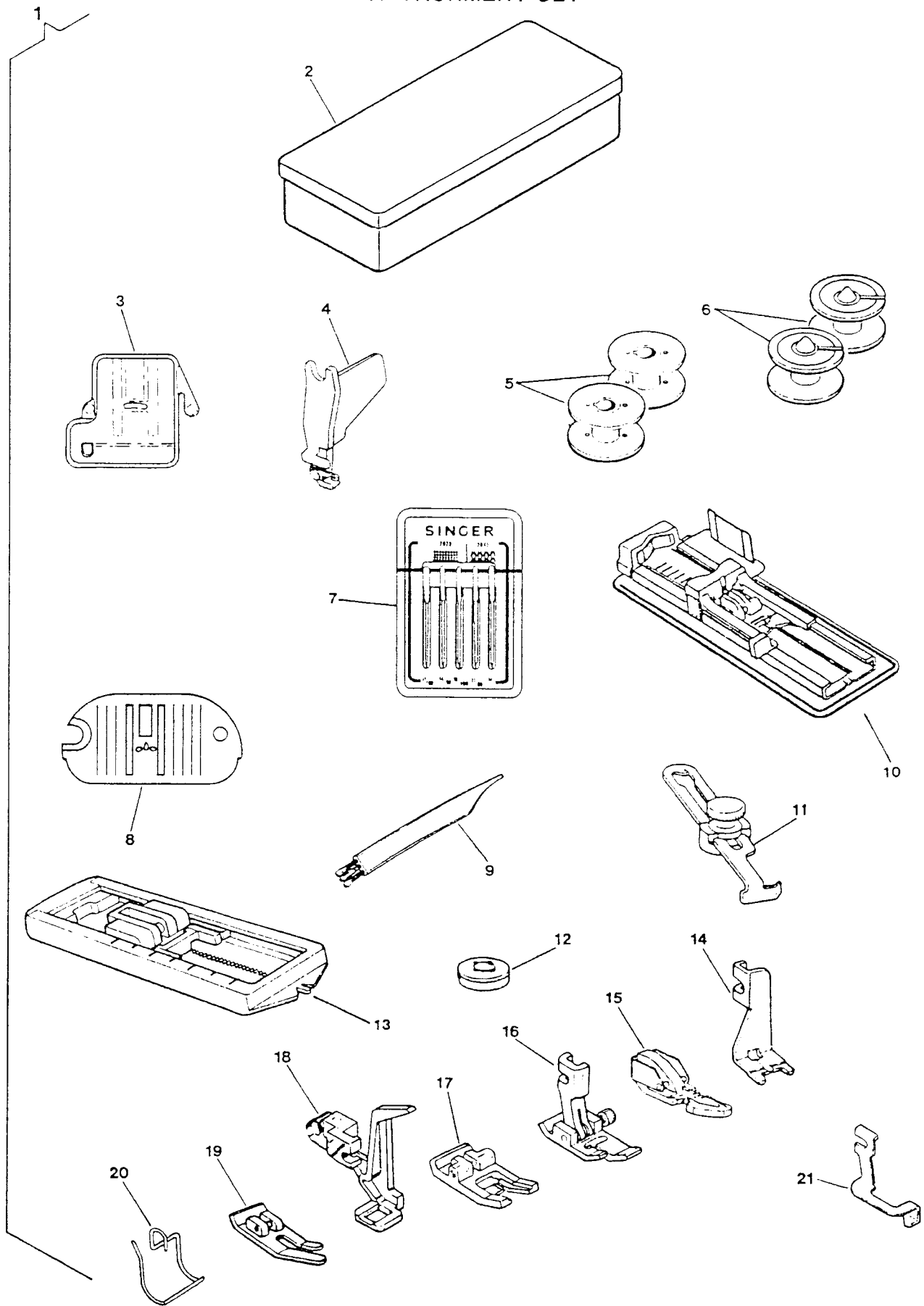

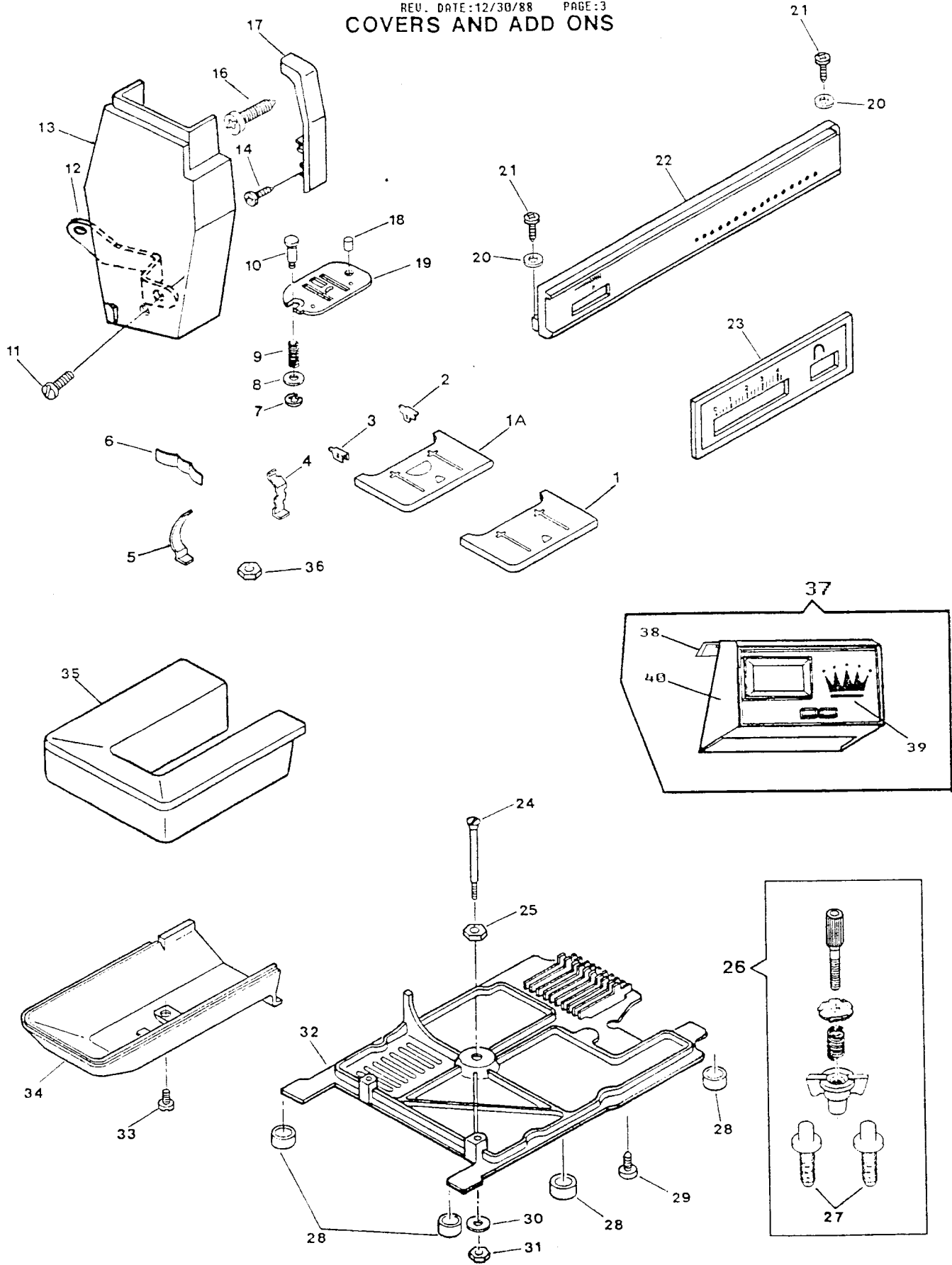

COVERS AND ADD ONS  
MODEL:9410

REF. PART NO.	PART NO.	DESCRIPTION
1	314666	BED SLIDE ASSEMBLY COMPL. (APOLLO)
2	314669	BED SLIDE SPRING (RIGHT)
3	314670	BED SLIDE SPRING (LEFT)
4	313178	BED SLIDE STOP
5	313179	BED SLIDE STOP SPRING
6	313118	CLOTH PLATE SPRING
7	313098	THROAT PLATE PLUNGER RETAINING RING
8	549426-451	THROAT PLATE PLUNGER WASEHR
9	312805	THROAT PLATE PLUNGER SPRING
10	312804	THROAT PLATE PLUNGER
11	113521-451	FACE PLATE MOUNTING SCREW
12	314263	FACE PLATE MOUNTING BRACKET
13	314259-451	FACE PLATE COMPLETE
14	113470-003	THREAD TAKE-UP COVER MOUNTING SCREW
16	113455-004	THREAD TAKE-UP COVER MOUNTING SCREW
17	314718-451	THREAD TAKE-UP COVER
18	353624	THROAT PLATE LOCATING PIN
19	312777	THROAT PLATE FOR ZIG ZAG SEWING
23	317009-004	STITCH LENGTH CONTROL PANEL (U.S./CANADA)
24	313052-451	BOTTOM COVER MOUNTING BOLT
25	313173-451	BOTTOM COVER MOUNTING BOLT MOUNTING NUT
26	313180	MACHINE HOLD DOWN MOUNTING KIT
27	148869	MACHINE LOCATOR PIN
28	313909-451	BEL LEG CUSHION
29	113455-002	BED COVER PLATE (BOTTOM) SCREW
30	314712-451	BOTTOM COVER MOUNTING BOLT WASHER
31	313177-452	BOTTOM COVER MOUNTING BOLT MOUNTING NUT
32	312774-001	BED COVER PLATE (BOTTOM)
33	354633-452	BED COVER (TUBULAR) SCREW
34	312773-451	BED COVER TUBULAR
35	313882-451	CLOTH PLATE ASSEMBLY
36	313049	BED INSERT NUT

ARM TOP COVER  
MODEL:9410

REF. PART NO.	PART NO.	DESCRIPTION
1	314384-451	ARM TOP COVER MACHINE HANDLE
2	314386	ARM TOP COVER MACHINE HANDLE HINGE BRACKET COMPLETE (2)
3	113520-451	ARM TOP COVER MACHINE HANDLE HINGE BRACKET SCREW (RIGHT & LEFT)
4	314485	ARM TOP COVER MACHINE HANDLE RETAINING SPRING
5	314561	ARM TOP COVER MACHINE HANDLE HINGE BRACKET NUT PLATE (LEFT)
6	314560	ARM TOP COVER MACHINE HANDLE HINGE BRACKET NUT PLATE (RIGHT)
7	317126-019	ARM TOP COVER ASSEMBLY (USA & CANADA)
8	314675	BOBBIN WINDER ASSEMBLY
9	314045-451	BOBBIN WINDER FRICTION RING
10	312897	BOBBIN WINDER LEVER SPRING
12	314672	BOBBIN WINDER LEVER HINGE STUD
14	314711-451	BOBBIN WINDER STOP SCREW NUT
15	312894	BOBBIN WINDER STOP
16	141808-453	BOBBIN WINDER STOP SCREW
17	313563	ARM TOP COVER THREAD GUIDE ASSEMBLY
18	354810-451	ARM TOP COVER THREAD GUIDE SCREW
19	313536	BOBBIN WINDER TENSION ASSEMBLY
20	179812	BOBBIN WINDER TENSION STUD
21	45847	BOBBIN WINDER TENSION DISC SPRING
22	45915	BOBBIN WINDER TENSION DISC
23	319606	BOBBIN WINDER TENSION STUD COLLAR
24	319663-452	BOBBIN WINDER TENSION STUD RETAINING RING
25	312940-451	SPOOL PIN (HORIZONTAL)
26	314337	ARM TOP COVER SUPPORT BRACKET
27	113442-002	ARM TOP COVER SUPPORT BRACKET SCREW (LEFT)
28	113516-451	ARM TOP COVER SUPPORT BRACKET SCREW (RIGHT)
29	179967-451	SPOOL PIN THREAD LEAD-OFF
30	354927-001	ARM TOP COVER MOUNTING SCREW (3)
31	312892	ARM TOP COVER MOUNTING PLATE (LEFT)
32	314275	ARM TOP COVER MOUNTING PLATE (RIGHT)



# ARM TOP COVER

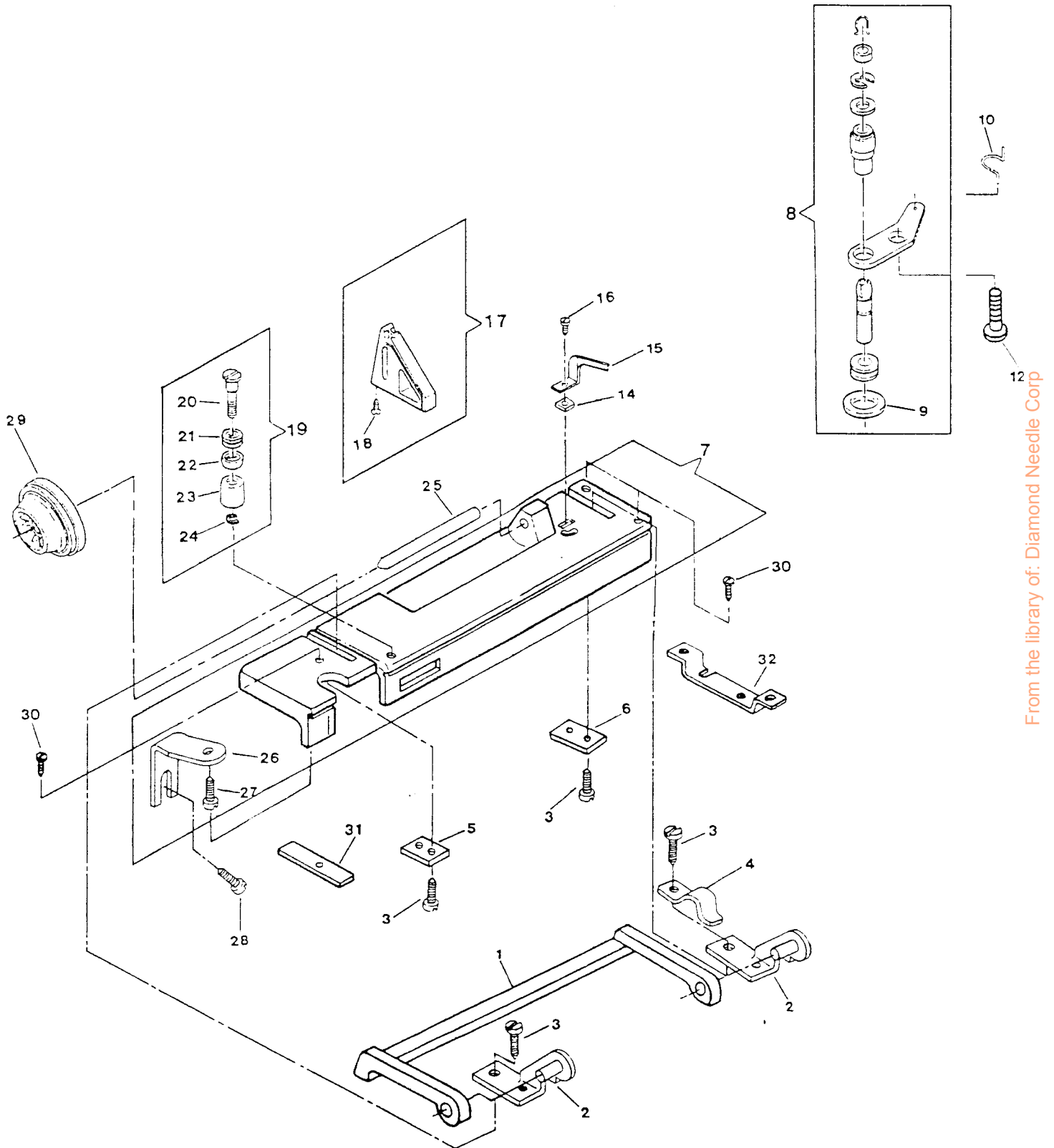

ARM SHAFT DRIVE SYSTEM  
MODEL:9410

REF. PART NO. NO.	DESCRIPTION
1 113455-001	ARM SHAFT (HORIZONTAL) BUSHING (LEFT & RIGHT) CLAMP SCREW
2 312796	ARM SHAFT (HORIZONTAL) BUSHING (LEFT & RIGHT) CLAMP ASSEMBLY
3 113488-451	THREAD TAKE-UP STUD SET SCREW
6 313982	ARM SHAFT HORIZONTAL ASSEMBLY
6 313989	ARM SHAFT HORIZONTAL ASSEMBLY (ALTERNATE TO 313982)
7 312620-001	ARM SHAFT (HORIZONTAL) RETAINING COLLAR THRUST WASHER (PLASTIC)
7A 312620-002	ARM SHAFT THRUST WASHER
8 312795	ARM SHAFT (HORIZONTAL) BUSHING (LEFT & RIGHT)
9 544208-001	ARM SHAFT (HORIZONTAL) RETAINING COLLAR SET SCREW
10 312619	ARM SHAFT (HORIZONTAL) RETAINING COLLAR ASSEMBLY
11 603975-011	BELT (ROTATING HOOK DRIVE ) ALT:603975-012
12 544212-003	ARM SHAFT (HORIZONTAL) BELT DRIVE PULLEY SCREW
13 314074-901	ARM SHAFT (HORIZONTAL) BELT DRIVE PULLEY (PLASTIC)
14 354591-451	DISC STACK DRIVING WORM GEAR SET SCREW
15 312623	DISC STACK DRIVING WORM GEAR ASSEMBLY
16 313153	HAND WHEEL RETAINING RING
17 314131	ROTATING HOOK DRIVE SHAFT BELT PULLEY ASSEMBLY
18 544098	ROTATING HOOK DRIVE SHAFT BELT PULLEY SET SCREW
19 113445-001	ROTATING HOOK DRIVE SHAFT BUSHING (SELF-ALIGNING) CLAMP SCREW
20 314013-451	ROTATING H. D. SHAFT BUSHING (SELF-ALIGNING) CLAMP SCREW LOCK WASHER
21 313816	ROTATING HOOK DRIVE SHAFT BUSHING (SELF-ALIGNING) CLAMP
22 312700-001	ROTATING HOOK DRIVE SHAFT BUSHING (RIGHT ) (SELF-ALIGNING)
23 444900-452	ROTATING HOOK DRIVE SHAFT SPRING WASHER
25 312685	ROTATING HOOK DRIVE SHAFT BEARING RETAINING RING
26 313920	FEED DRIVE SHAFT DRIVING GEAR ASSEMBLY
27 113466-451	FEED DRIVE SHAFT GEAR SET SCREW
28 313936	ROTATING HOOK DRIVE SHAFT
29 312700-002	ROTATING HOOK DRIVE SHAFT BUSHING (LEFT) (SELF-ALIGNING)
31 544208-005	ROTATING HOOK DRIVE SHAFT BEVEL GEAR SET SCREW
32 314011	ROTATING HOOK DRIVE SHAFT BEVEL GEAR ASSEMBLY ALT:314054-900
33 313195	IDLER BRACKET ASSEMBLY
34 313157	BELT IDLER PULLEY RETAINING RING
35 382255	BELT IDLER PULLEY
36 313001	IDLER BRACKET ASSEMBLY
39 113455-002	ROTATING HOOK DRIVING BELT TENSION ADJUSTER SCREW
40 314041-451	ROTATING HOOK DRIVING BELT TENSION ADJUSTER SCREW WASHER
41 314013-451	ARM SHAFT BUSHING (LAMP SCREW WASHER)

# ARM SHAFT DRIVE SYSTEM

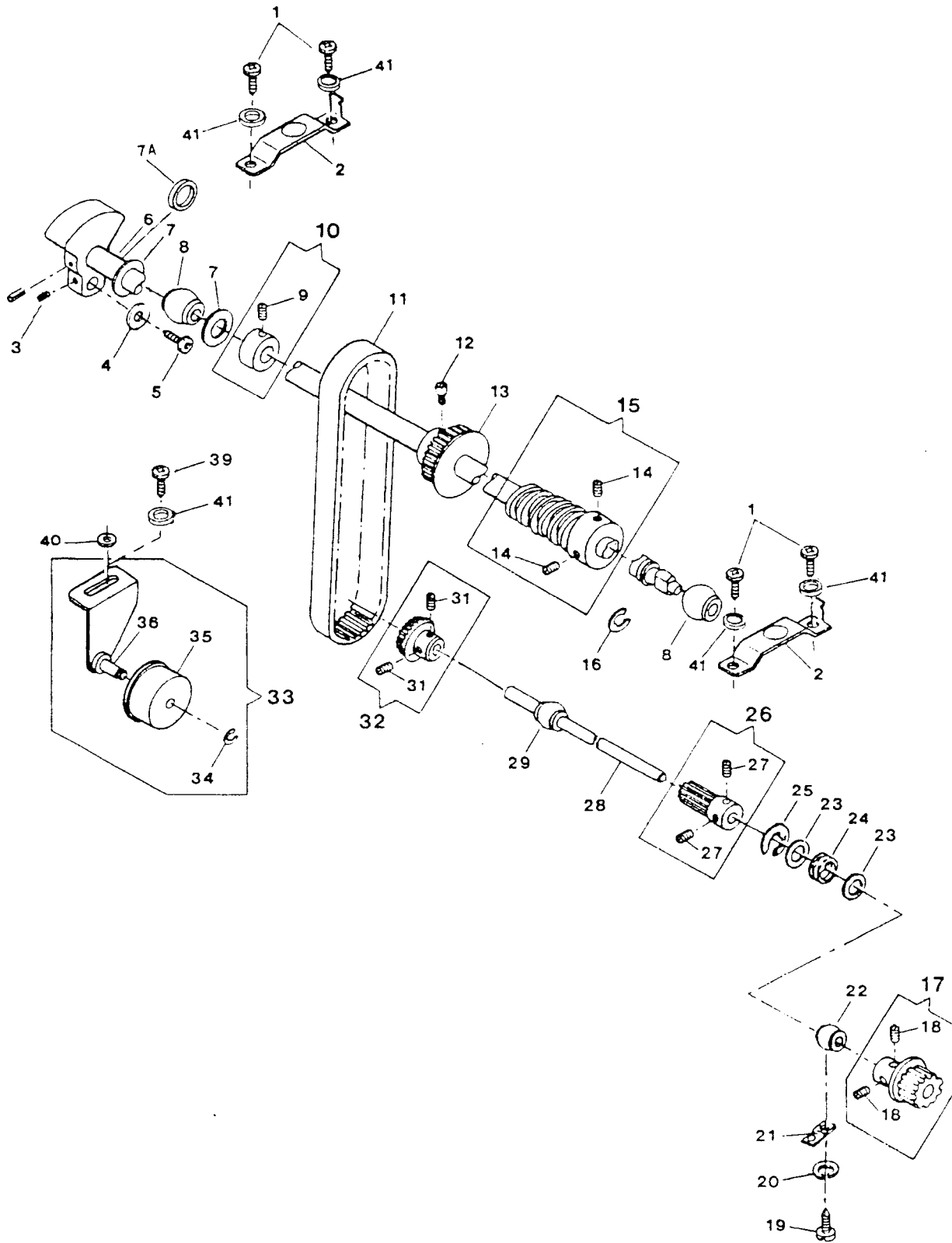

# HAND WHEEL

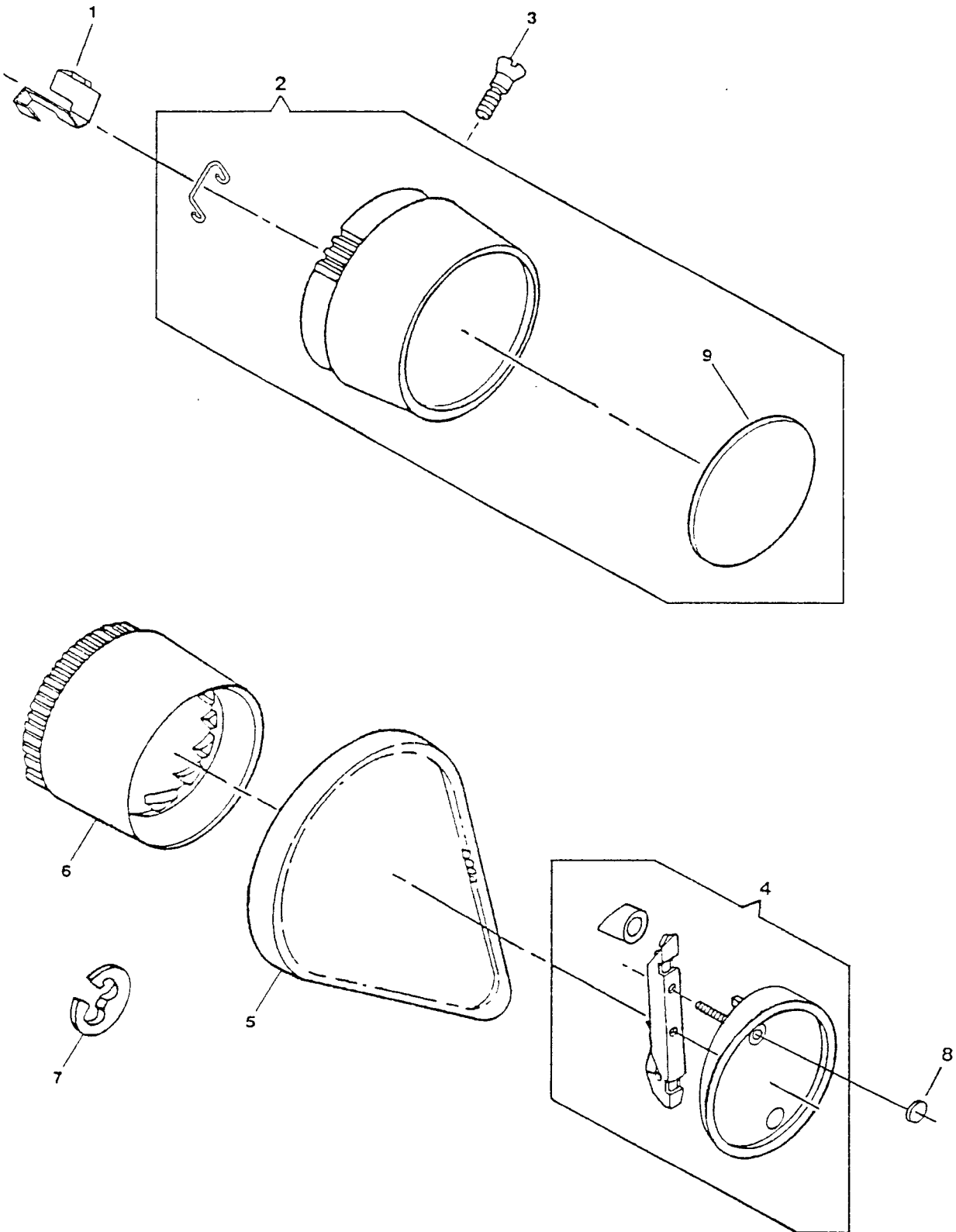

HAND WHEEL  
MODEL:9410

REF. PART NO.	NO.	DESCRIPTION
4	313185-451	HAND WHEEL CLUTCH PLATE ASSEMBLY
5	312628-001	BELT (MOTOR DRIVE) ALT: 979285-001
6	312625-451	HAND WHEEL (PLASTIC)
7	313153	HAND WHEEL RETAINING RING
8	314733-900	HAND WHEEL ACCESS PLATE (APOLLO)

COAXIAL PRESSER BAR SYSTEM FOR NEW HEAD END  
MODEL:9410

REF. PART NO.	NO.	DESCRIPTION
1	314696	HEAD END MOUNTING PLATE ASSEMBLY COMP.
2	314582	PRESSER BAR LIFTER
3	314580	NEEDLE BAR & PRESSER BAR ADJUSTING BRACKET (SUB-ASSEMBLY)
4	544208-001	NEEDLE BAR VIBRATING BRACKET BALL BUSHING (UPPER) ADJUSTER SET SCREW
5	113485-452	NEEDLE BAR PRESSER BAR ADJUSTING BRACKET MOUNTING SCREW
6	314583-901	PRESSER BAR GUIDE BRACKET
7	141936-833	PRESSER BAR GUIDE BRACKET SCREW
8	314584	PRESSER BAR SPRING RETAINING RING (UPPER)
9	353214	PRESSER BAR SPRING
10	314585	PRESSER BAR SPRING RETAINING RING (LOWER)
11	314591	FACE PLATE MOUNTING BRACKET
12	313955-451	HEAD END MOUNTING PLATE LOCK WASHER
13	113455-012	HEAD END MOUNTING PLATE SCREW
14	314581	PRESSER BAR
15	163706-451	PRESSER FOOT SHANK (SNAP-ON)
16	313150	PRESSER FOOT PLATE (SNAP-ON) FOR ZIG-ZAG SEWING
17	113531-451	PRESSER FOOT THUMB SCREW
19	113455-001	NEEDLE THREAD TENSION RELEASE LEVER HINGE SCREW
20	314041-451	NEEDLE THREAD TENSION RELEASE LEVER RETAINING WASHER
21	314589	NEEDLE THREAD TENSION RELEASE LEVER ASSEMBLY

# COAXIAL PRESSER BAR SYSTEM

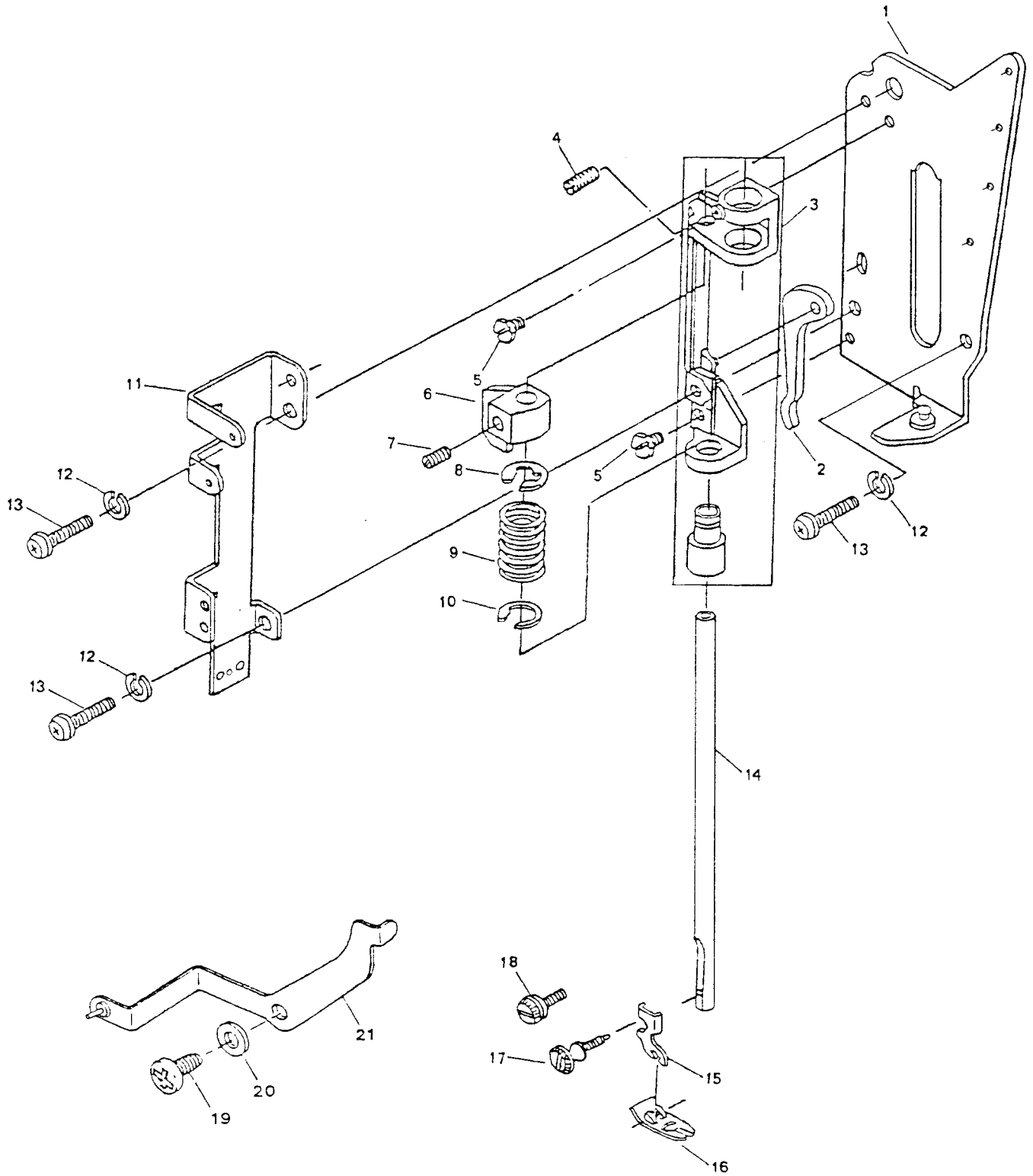

### NEEDLE BAR AND THREAD TAKE-UP

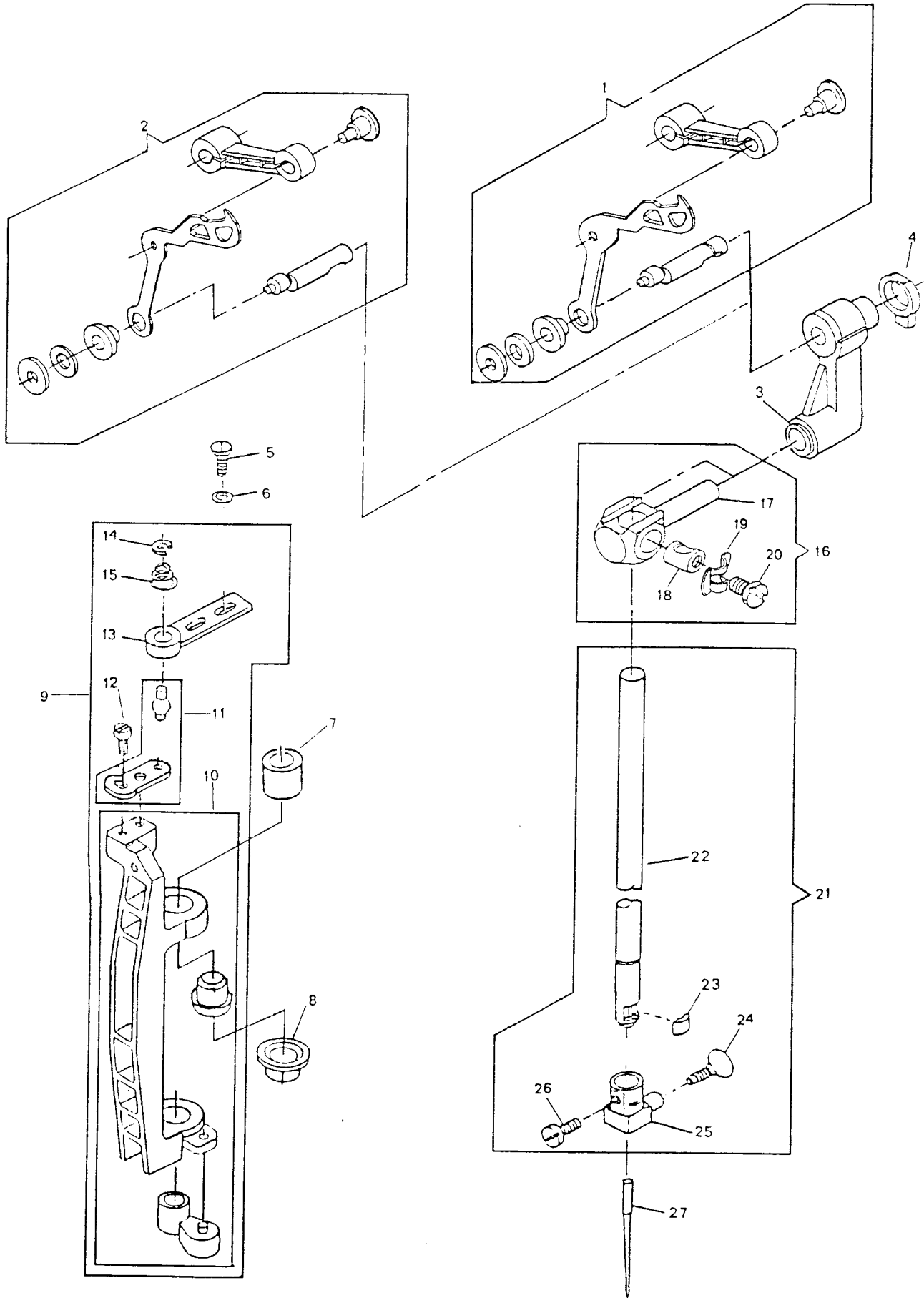



NEEDLE BAR & THREAD TAKE-UP FOR NEW HEAD END  
MODEL:9410

REF. PAF NO.	NO.	DESCRIPTION
1	314694	THREAD TAKE-UP COMPLETE (APOLLO)
3	313533	NEEDLE BAR CONNECTING LINK ASSEMBLY
4	314146	NEEDLE BAR CONNECTING LINK SPACER
5	113408-001	NEEDLE BAR DRIVING ARM BALL JOINT SCREW
6	931929-004	NEEDLE BAR DRIVING ARM BALL JOINT SCREW WASHER
7	314574	NEEDLE BAR VIBRATING BRACKET BUSHING (UPPER)
8	314573	NEEDLE BAR BALL BUSHING SOCKET (LOWER)
9	314569	NEEDLE BAR VIBRATING BRACKET ASSEMBLY
10	314614	NEEDLE BAR VIBRATING BRACKET SUB-ASSEMBLY
11	314570	NEEDLE BAR VIBRATING BRACKET STUD PLATE ASSEMBLY
12	141920-451	NEEDLE BAR VIBRATING BRACKET STUD PLATE ASSEMBLY MOUNTING SCREW
13	312839	NEEDLE BAR DRIVING ARM BALL JOINT
14	312702	NEEDLE BAR DRIVING ARM BALL JOINT RETAINING RING
15	382602	NEEDLE BAR DRIVING ARM BALL JOINT SPRING
16	313191	NEEDLE BAR CONNECTING STUD SUB-ASSEMBLY
17	312751	NEEDLE BAR CONNECTING STUD
18	312769	NEEDLE BAR CONNECTING STUD HINGE PIN
19	384000	NEEDLE BAR CONNECTING STUD HINGE PIN FRICTION WASHER
20	354972-451	NEEDLE BAR CLAMPING & GUIDE SCREW
21	313192	NEEDLE BAR SUB-ASSEMBLY
22	313553	NEEDLE BAR
23	313552	NEEDLE BAR GIB
24	354898-451	NEEDLE THUMB SCREW
25	313798	NEEDLE CLAMP BODY
26	141920-454	NEEDLE CLAMP BODY NEEDLE CLAMP THREAD GUIDE & NEEDLE STOP SCREW
27	N2045	NEEDLE SIZE NO. 14 (IN MACHINE)

ALPHA FEED  
MODEL:9410

REF. PAPP NO. NO.	DESCRIPTION
1 141920-452	FEED DOG SCREW
2 312679	FEED DOG (APOLLO)
2 313171	FEED DOG (APOLLO) (ALTERNATE PYRAMID)
3 314140-002	ALPHA FEED MODULE
4 511213	FEED DOG HOLDER STUD RETAINING RING
5 511052	FEED DOG HOLDER STUD
6 422334-902	FEED DOG HOLDER (MACHINED)
7 544100	FEED DOG HOLDER STUD SCREW
8 511210	FEED DOG HOLDER WASHER
9 354983-451	FEED BAR CONNECT'G & FEED LIFT'G FORK CONNECT'G HINGE STUD (ECCENTRIC) SET SCREW (ALT: 354420-451)
10 422561	FEED DOG HOLDER COMPENSATING LINK RETAINING SPRING (FRONT)
11 422337	FEED DOG HOLDER COMPENSATING LINK RETAINING SPRING (BACK)
12 422335-001	FEED DOG HOLDER COMPENSATING LINK
13 514744-451	FEED BAR PIVOT HINGE STUD LOCK SCREW
14 314142	FEED BAR PIVOT HINGE STUD PIN
15 422338	FEED BAR HINGE PIN WASHER
16 422333-902	FEED BAR
17 511211	FEED BAR GUIDE HINGE PIN SPRING WASHER
18 422340-001	FEED BAR PIVOT HINGE STUD
19 314141	FEED BAR ASSEMBLY
20 312851	FEED BAR PIVOT HINGE STUD CLAMP
21 113455-003	FEED BAR PIVOT HINGE STUD CLAMP SCREW

# ALPHA FEED

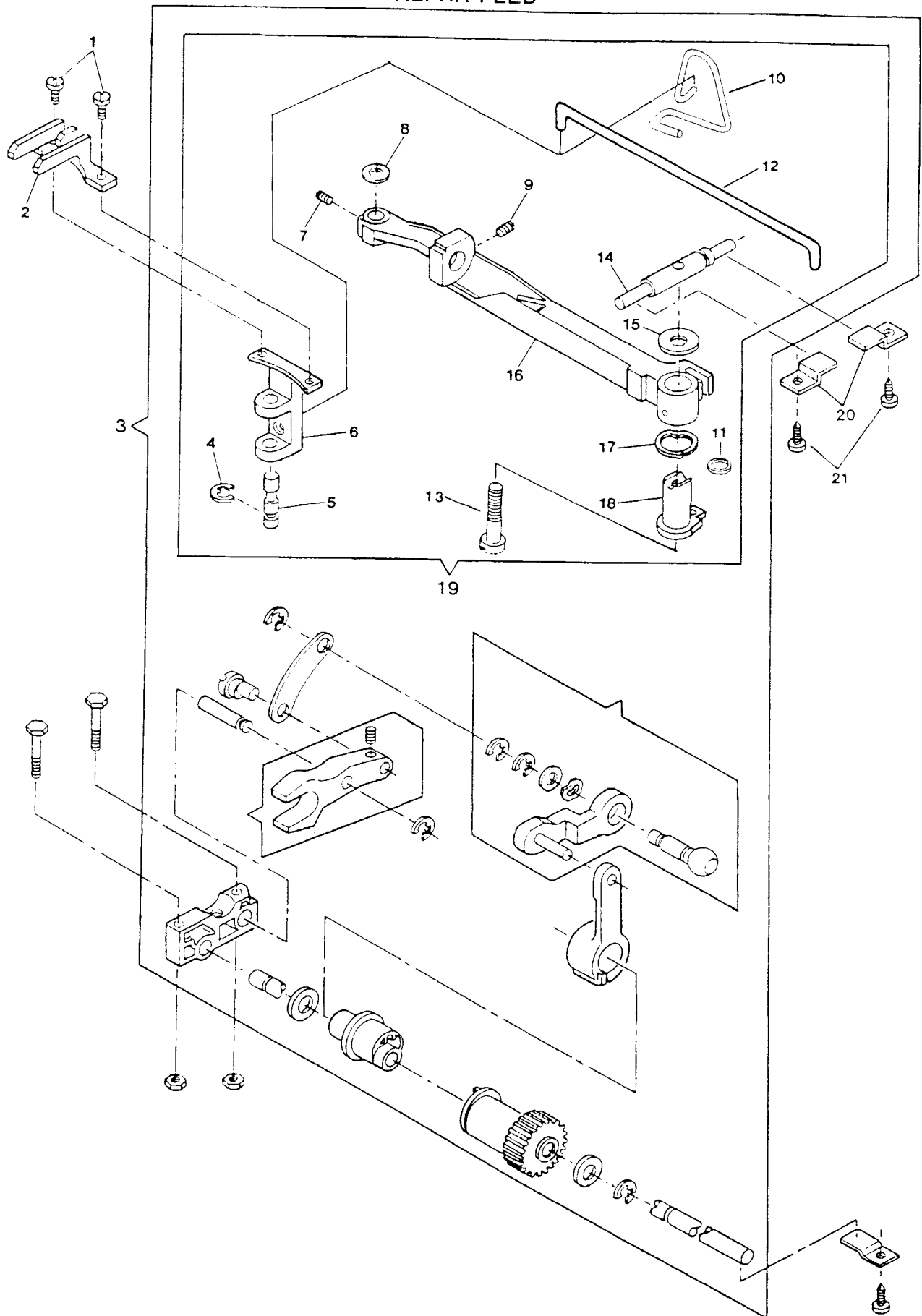

# ALPHA FEED (CONT.)

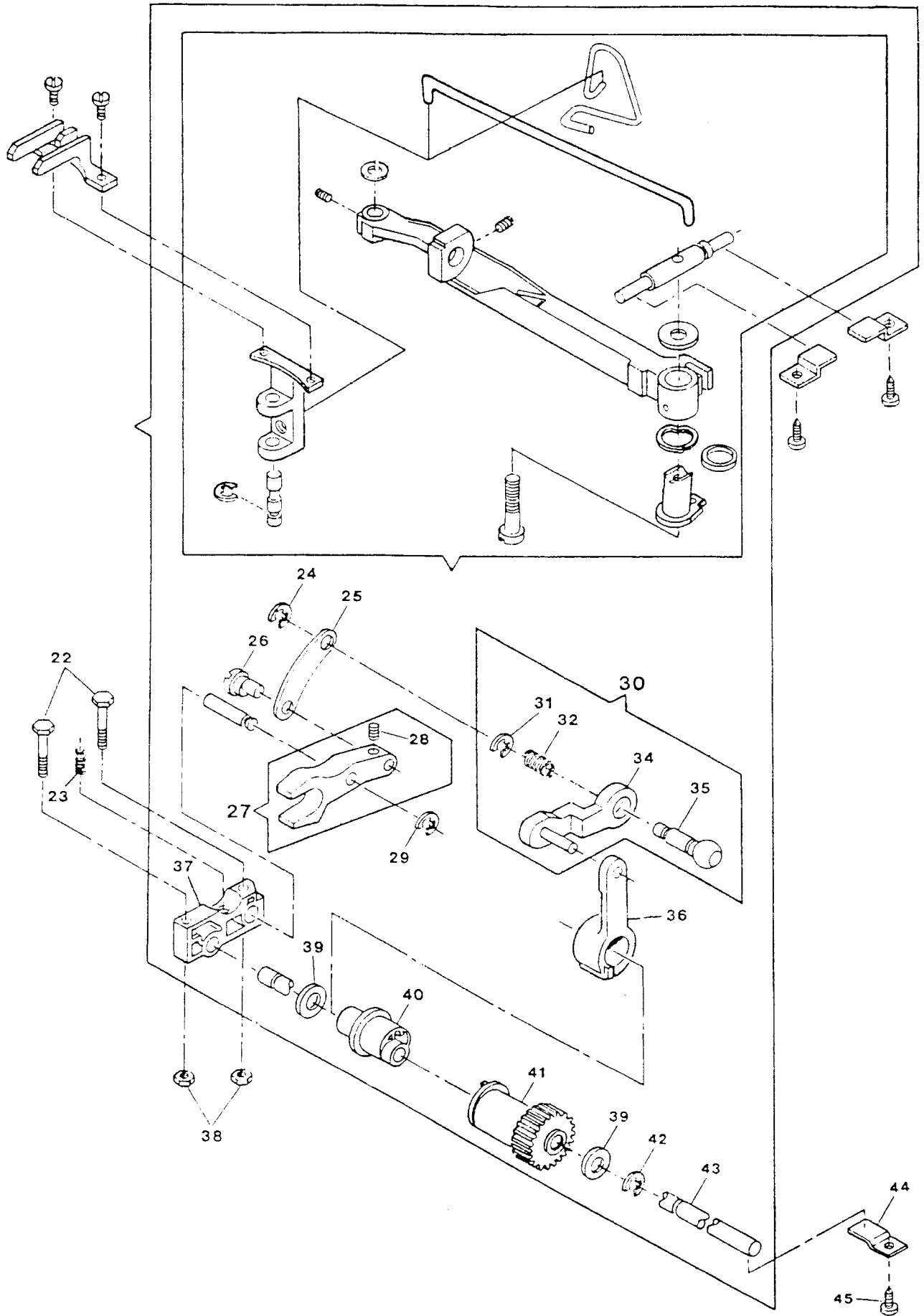

ALPHA FEED (CONT.)  
MODEL:9410

REF. PART NO. NO.	DESCRIPTION
22 354921-451	FEED & ROTATING HOOK DRIVE SHAFT BEARING BLOCK MOUNTING SCREW
23 314070	ROTATING HOOK DRIVE SHAFT BUSHING SPRING
24 312686	FEED LIFTING FORK CONNECTING RETAINING RING
25 511016	FEED LIFTING FORK CONNECTION
26 511056	FEED LIFTING FORK CONNECTING HINGE STUD (ECCENTRIC)
27 503325-002	FEED LIFTING FORK COMPL.
28 514685-451	FEED LIFTING FORK CONNECTING HINGE STUD (ECCENTRIC) SET SCREW
29 312685	FEED & ROTATING HOOK DRIVE SHAFT BEARING BLOCK STUD RETAINING RING
30 313910	FEED BAR CONNECTION ASSEMBLY COMPLETE
31 312685	FEED BAR CONNECTION AND FEED LIFTING FORK CONNECTION HINGE STUD (ECCENTRIC) RETAINING RING
32 314030	FEED BAR CONNECTION SPRING
34 313130	FEED BAR CONNECTION ASSEMBLY
35 313456	FEED BAR CONNECTION AND FEED LIFTING FORK CONNECTION HINGE STUD (ECCENTRIC) ALT: 312852
36 312872-900	FEED REGULATOR SLIDE BLOCK DRIVE CONNECTION
37 312864	FEED & ROTATING HOOK DRIVE SHAFT BEARING BLOCK ASSEMBLY
38 514674-451	FEED & ROTATING HOOK DRIVE SHAFT BEARING BLOCK MOUNTING SCREW NUT
39 312879-451	FEED DRIVE SHAFT GEAR WASHER
40 312869	FEED LIFTING CAM & FEED ECCENTRIC (APOLLO)
41 312902	FEED DRIVE SHAFT GEAR (PLASTIC)
42 312686	FEED DRIVE SHAFT GEAR RETAINING RING
43 312862-900	FEED DRIVE SHAFT
44 312851	FEED DRIVE SHAFT CLAMP
45 113455-003	FEED DRIVE SHAFT CLAMP SCREW

ALPHA FEED (CONT.)  
MODEL:9410

REF. PART NO.	NO.	DESCRIPTION
1	313133	FEED REGULATOR SHAFT ASSEMBLY
2	511030	FEED REGULATOR SLIDE BLOCK
3	312874	FEED REGULATOR COMPL.
4	113515-451	FEED REGULATOR SCREW
5	314173	FEED REGULATOR SHAFT
6	312700-002	FEED REGULATOR SHAFT BUSHING (SELF-ALIGNING)
7	314175	FEED REGULATOR SHAFT TENSION SPRING ADJUSTING COLLAR ASSEMBLY
8	544207-001	FEED REGULATOR SHAFT TENSION SPRING ADJUSTING COLLAR SCREW
9	314172	FEED REGULATOR SHAFT TENSION SPRING
10	312875	FEED REGULATOR SHAFT RETAINING RING
11	312801	STITCH LENGTH CONTROL CRANK
12	354922-451	STITCH LENGTH CONTROL CRANK SCREW
13	313816	FEED REGULATOR SHAFT BUSHING (SELF-ALIGNING) CLAMP
14	314013-451	FEED REGULATOR SHAFT BUSHING (SELF-ALIGNING) CLAMP SCREW LOCK WASHER
15	113455-001	FEED REGULATOR SHAFT BUSHING (SELF-ALIGNING) CLAMP SCREW

### ALPHA FEED (CONT.)

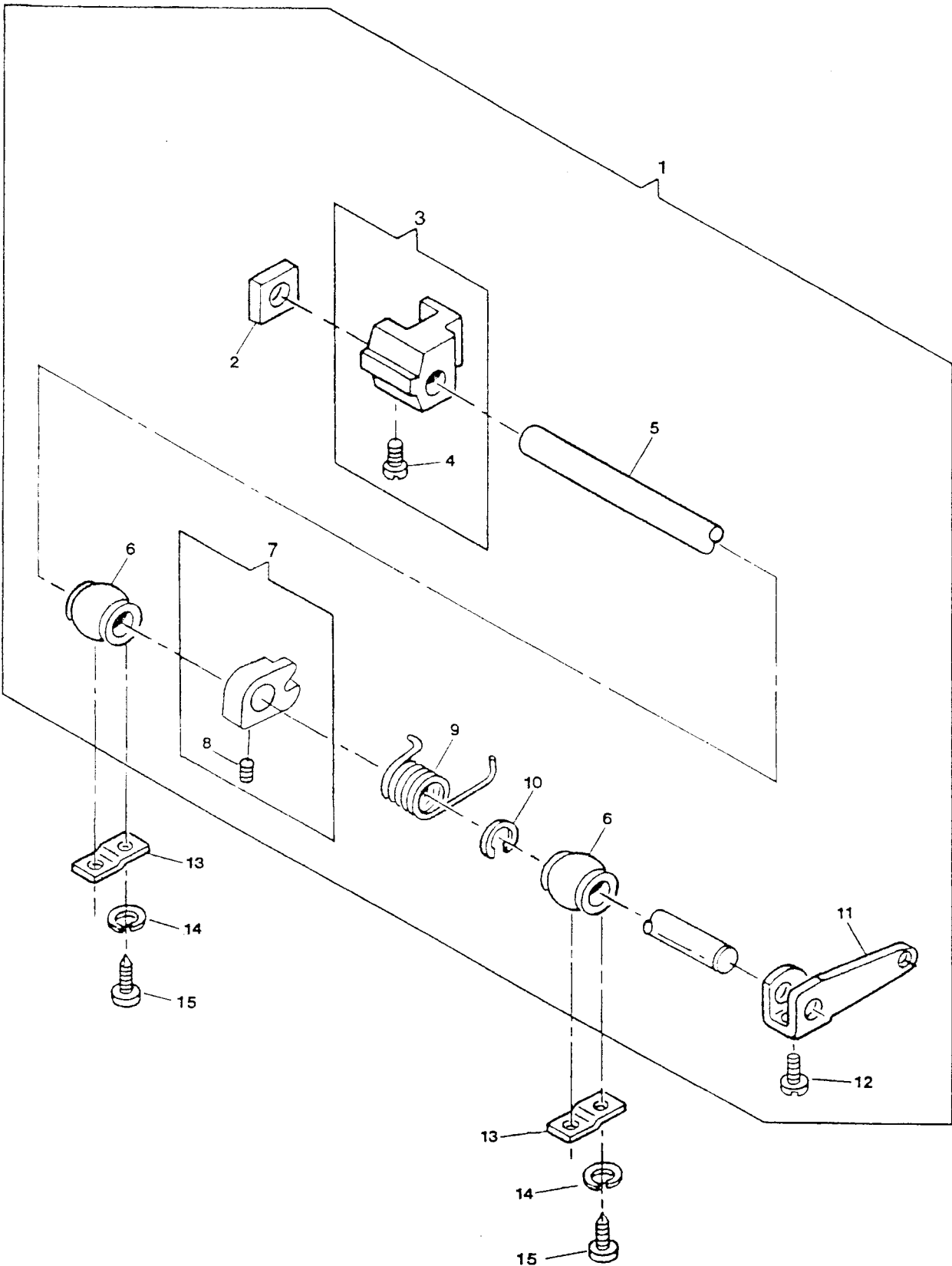

# HOOK SYSTEM (APOLLO)

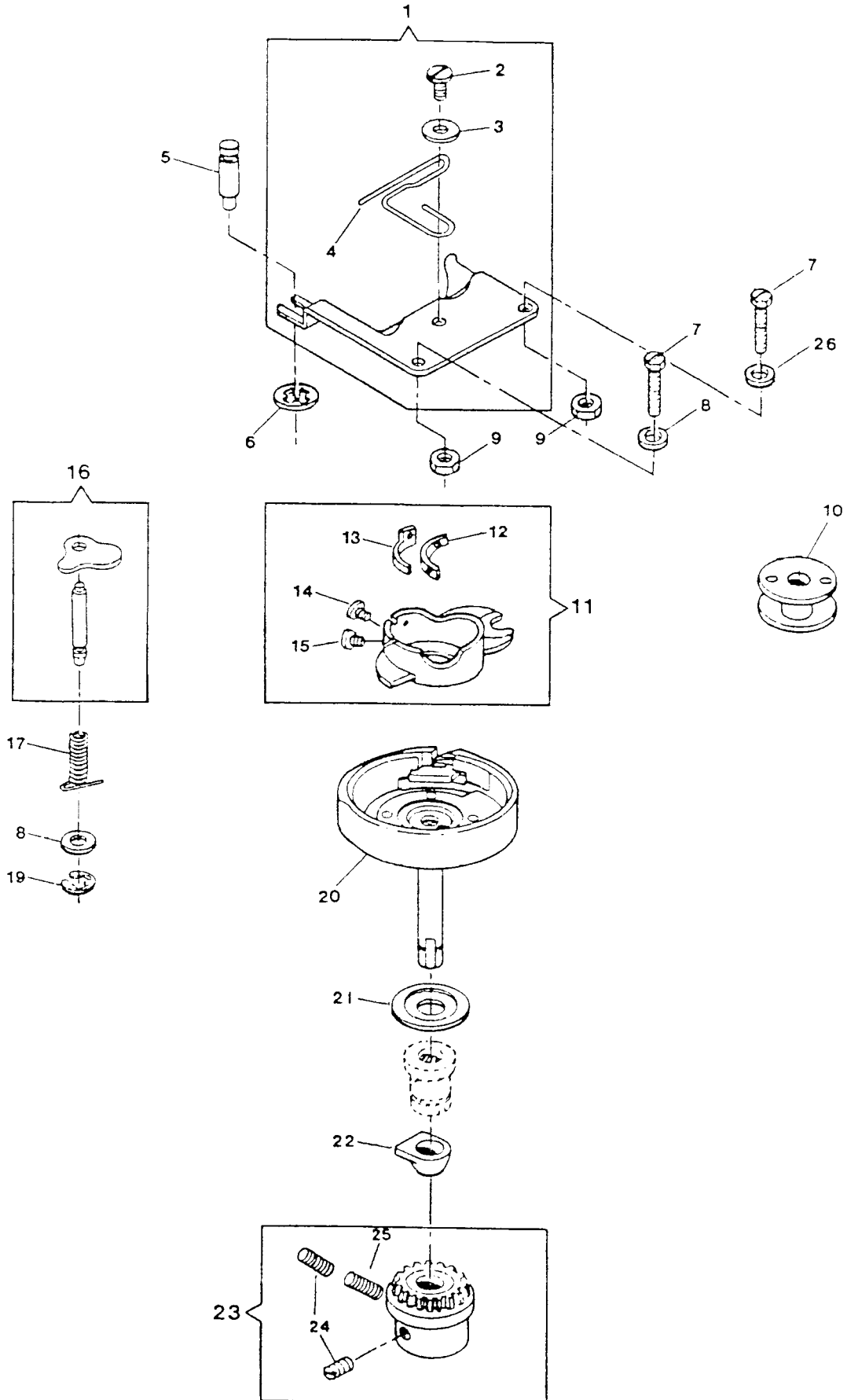



HOOK SYSTEM (APOLLO)  
MODEL:9410

REF. PART NO. NO.	DESCRIPTION
1 313089	ROTATING HOOK BOBBIN CASE POSITION PLATE ASSEMBLY
1 314066	ROTATING HOOK BOBBIN CASE POSITION PLATE ASSEMBLY (ALTERNATE TO 313089)
2 354883-451	ROTATING HOOK BOBBIN CASE CUSHION SPRING SCREW
3 313190-451	ROTATING HOOK BOBBIN CASE CUSHION SPRING SCREW WASHER
4 313067-900	ROTATING HOOK BOBBIN CASE CUSHION SPRING
5 312603	ROTATING HOOK BOBBIN CASE POSITION PLATE HOLD DOWN STUD
6 313161	ROTATING HOOK BOBBIN CASE POSITION PLATE HOLD DOWN STUD RETAINING RING
7 113439-451	ROTATING HOOK BOBBIN CASE POSITION PLATE SCREW
8 313190-451	ROTATING HOOK BOBBIN CASE POSITION PLATE SCREW WASHER (LEFT)
9 313945-451	ROTATING HOOK BOBBIN CASE POSITION PLATE SCREW NUT
10 172336	ROTATING HOOK BOBBIN (PLASTIC)
11 421325	ROTATING HOOK BOBBIN CASE COMPLETE
12 310884-452	ROTATING HOOK BOBBIN CASE TENSION SPRING SEGMENT
13 310883	ROTATING HOOK BOBBIN CASE TENSION SPRING
14 139975-452	ROTATING HOOK BOBBIN CASE TENSION SPRING SEGMENT SCREW
15 354183-452	ROTATING HOOK BOBBIN CASE TENSION REGULATING SCREW
16 312846	ROTATING HOOK BOBBIN CASE RETAINING PLATE SUB ASSEMBLY
17 312607	ROTATING HOOK BOBBIN CASE RETAINING PLATE STUD SPRING
18 313190-451	ROTATING HOOK BOBBIN CASE RETAINING PLATE STUD WASHER
19 313783	ROTATING HOOK BOBBIN CASE RETAINING PLATE STUD RETAINING RING
20 314025	ROTATING HOOK COMPLETE (ALTERNATE TO 313034)
21 314049	ROTATING HOOK FLANGED BUSHING THRUST WASHER
22 312847	ROTATING HOOK FLANGED BUSHING WASHER
23 314101-900	ROTATING HOOK BEVEL GEAR COMPLETE (ALT: 314012)
24 544207-012	ROTATING HOOK BEVEL GEAR (PLASTIC) SET SCREW
25 544207-011	ROTATING HOOK BEVEL GEAR SET SCREW

# PATTERN STITCH LENGTH CONTROL AND CAM CONTROLLED FEED

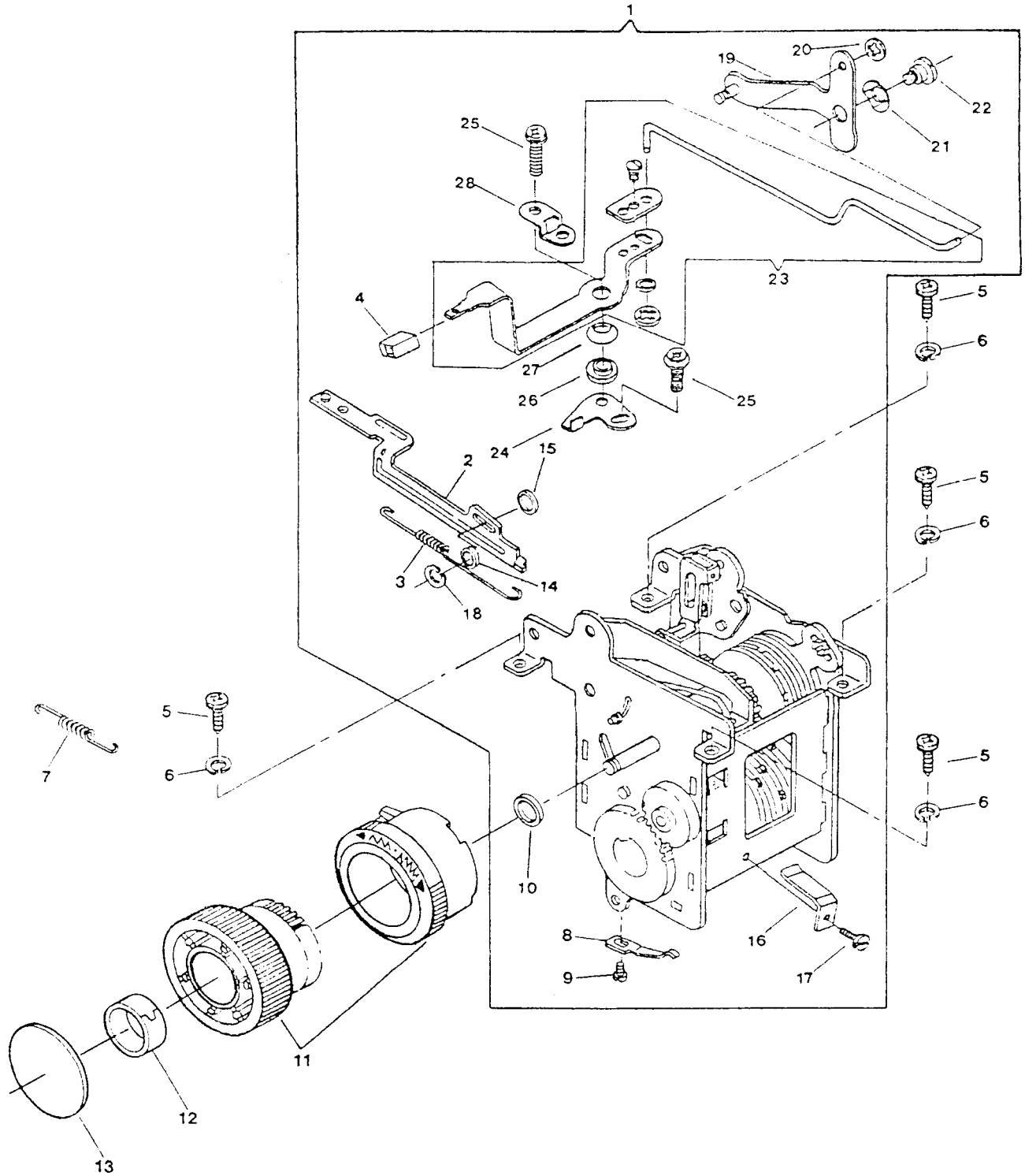

PATTERN STITCH LENGTH CONTROL & CAM CONTROLLED FEED  
MODEL:9410

REF. PART NO. NO.	DESCRIPTION
1 314601-001	PATTERN SELECTOR MODULE
2 314492	NEEDLE BAR DRIVING ARM
3 313053	NEEDLE BAR DRIVING ARM RETURN SPRING
4 314676-459	BIGHT AMPLITUDE CONTROL LEVER KNOB (PLASTIC)(USA & CANADA)
5 113455-001	DISC SELECTOR MECHANISM MOUNTING PLATE SCREW (LEFT & RIGHT)
6 314013-451	DISC SELECTOR MECHANISM MOUNTING PLATE SCREW (LEFT & RIGHT) LOCK WASHER
7 314497	NEEDLE BAR DRIVING ARM SLIDE POSITIONING SPRING
8 313113	PATTERN SELECTOR INDICATOR DETENT SPRING
9 354899-451	PATTERN SELECTOR INDICATOR DETENT SCREW
10 314153	PATTERN SELECTOR KNOB SPACER
11 314239-460	PATTERN SELECTOR KNOB AND STITCH BALANCE KNOB
12 313535	PATTERN SELECTOR KNOB COMPRESSION RING
13 314744-465	PATTERN SELECTOR KNOB TRIM PLATE (USA & CANADA)
14 314493	STITCH WIDTH CONTROL BRACKET WASHER (FRONT)
15 314494	STITCH WIDTH CONTROL BRACKET WASHER (BACK)
18 314502	BIGHT AMPLITUDE CONTROL BRACKET RETAINING RING
19 314603	BIGHT AMPLITUDE CONTROL BRACKET ASSEMBLY
20 314606	BIGHT AMPLITUDE CONTROL ROD RETAINING RING (LEFT)
21 312879-451	BIGHT AMPLITUDE CONTROL LEVER WASHER
22 354875-451	BIGHT AMPLITUDE CONTROL BRACKET PIVOT SCREW
23 314607	BIGHT AMPLITUDE CONTROL LEVER ASSEMBLY
24 314610	BIGHT AMPLITUDE CONTROL LEVER STOP
25 113455-014	BIGHT AMPLITUDE CONTROL LEVER STOP ADJUSTMENT SCREW
26 314611	BIGHT AMPLITUDE CONTROL LEVER SHOULDER WASHER
27 353457	BIGHT AMPLITUDE CONTROL LEVER FRICTION WASHER
28 314683	BIGHT AMPLITUDE CONTROL LEVER RETAINER

PATTERN STITCH LENGTH CONTROL AND CAM CONTROLLED FEED (CONT.)

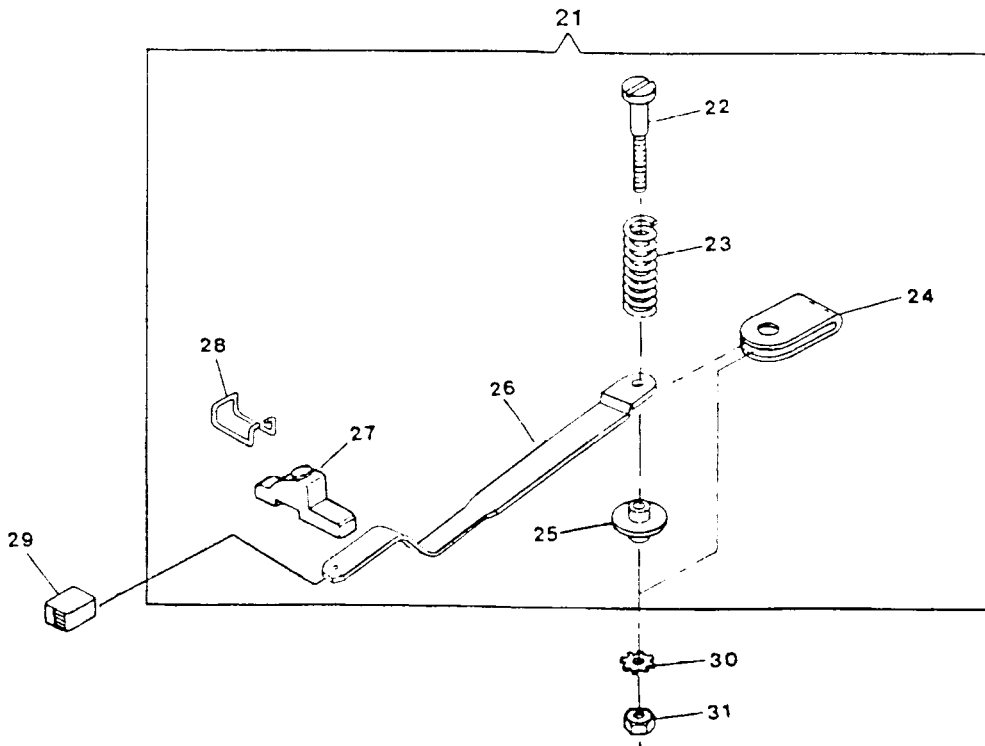
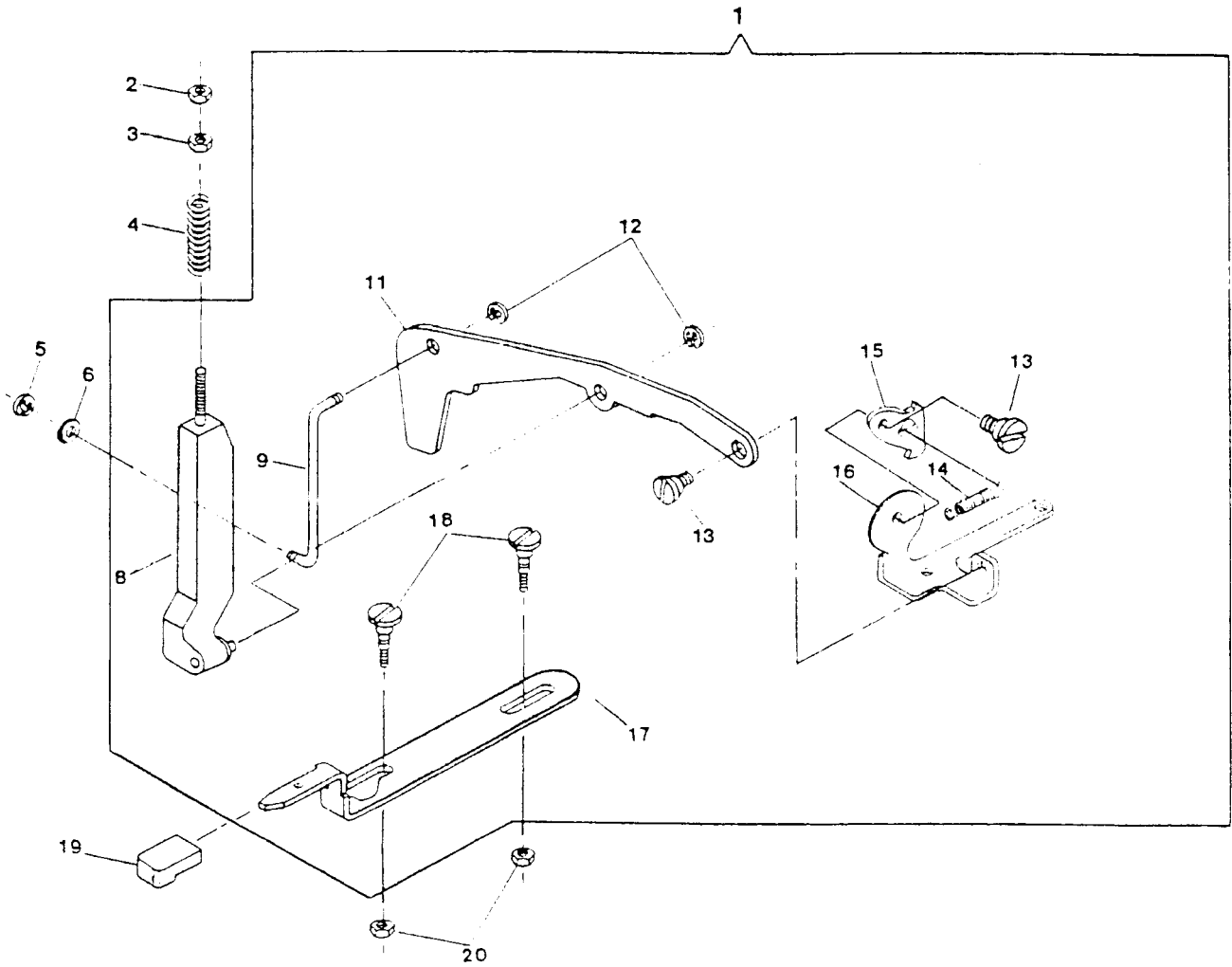

PATTERN, STITCH LENGTH CONTROL & CAM CONTROLLED FEED (CONT.)  
MODEL:9410

REF. NO.	PART NO.	DESCRIPTION
1	314300-001	FEED REVERSE MECHANISM
2	514674-451	CAM CONTROLLED FEED CONNECTING ROD LOCKING NUT
3	312645-451	CAM CONTROLLED FEED DISC FOLLOWER ACTUATOR CONNECTING ROD ADJUSTING NUT
4	313143	CAM CONTROLLED FEED DISC FOLLOWER ACTUATOR CONNECTING ROD SPRING
5	312702	FEED LEVER CONNECTING LINK RETAINING RING
6	313891	CAM CONTROLLED FEED CONNECTING ROD STABILIZING WASHER
8	314549	CAM CONTROLLED FEED DISC FOLLOWER ACTUATOR CONNECTING ROD
9	313057	FEED LEVER CONNECTING LINK
11	314283	STITCH LENGTH CONTROL ARM
12	312702	CAM CONTROLLED FEED DISC FOLLOWER ACTUATOR CONNECTING ROD RETAINING RING
13	354958-451	REVERSE FEED LEVER PIVOT SCREW
14	314282	REVERSE FEED CRANK SPRING
15	314281	REVERSE FEED CRANK
16	314279-900	REVERSE FEED LEVER MOUNTING BRACKET
17	314280	REVERSE FEED CONTROL LEVER
18	113499-451	REVERSE FEED CONTROL LEVER & LATCH SCREW
19	312657-459	REVERSE FEED CONTROL LEVER KNOB (PLASTIC) (USA & CANADA)
20	514674-451	REVERSE FEED CONTROL LEVER GUIDE SCREW NUT
21	313569	STITCH LENGTH CONTROL LEVER ASSEMBLY
22	113356-451	STITCH LENGTH CONTROL LEVER PIVOT SCREW
23	313567	STITCH LENGTH CONTROL LEVER SPRING
24	313566	STITCH LENGTH CONTROL FRICTION WASHER
25	313565-451	STITCH LENGTH CONTROL LEVER NUT
26	312663	STITCH LENGTH CONTROL LEVER
27	313960	STITCH LENGTH CONTROL LEVER CAM ASSEMBLY
28	313188	STITCH LENGTH CONTROL LEVER CAM RETAINING CLIP
29	312664-459	STITCH LENGTH CONTROL LEVER KNOB (PLASTIC) (USA & CANADA)
30	313172-451	STITCH LENGTH CONTROL LEVER PIVOT LOCK WASHER
31	313177-451	STITCH LENGTH CONTROL LEVER NUT

DEMAND RESPONSIVE NEEDLE TENSION SYSTEM  
MODEL:9410

QTY.	PART NO.	DESCRIPTION
	313199	TENSION COVER MOUNTING RETAINER
	313077-007	THREAD TENSION MODULE (USA & CANADA)
3	314299-451	TENSION REGULATOR LEVER STUD NUT
4	312708	TENSION SPRING
5	312710	TENSION SPRING WASHER
6	314002	TENSION MOUNTING PLATE SUB-ASSEMBLY TAKE-OFF
7	113442-003	TENSION COVER MOUNTING SCREW
8	53641	TENSION COVER RETAINING STUD NUT
9	312703	TENSION DISC
9	313403	TENSION DISC (ALTERNATE TO 312703)
11	312705	TENSION RELEASE PIN
12	314005	PRE-TENSION SPRING
13	312707	TENSION LEVER
13	313904	TENSION LEVER (ALTERNATE)
14	313048	TENSION REGULATING LEVER SLIDE BLOCK
15	312946	TENSION REGULATING LEVER ASSEMBLY
16	313015-007	TENSION COVER ASSEMBLY
17	312664-459	TENSION REGULATING KNOB (USA & CANADA)
18	313047	TENSION COVER RETAINING CLIP
19	314309	TENSION COVER SPACER (UPPER)
20	314685-900	THREAD WEAR PLATE (APOLLO)
21	314687-900	THREAD GUIDE
22	314688	THREAD TAKE-UP WEAR PLATE ASS'Y (APOLLO)
23	314690	THREAD PINCH PLATE
24	314686-900	THREAD GUIDE RIVET
25	317166	PINCH PLATE MOUNTING SCREW WASHER
26	113524-451	MOUNTING SCREW

# DEMAND RESPONSIVE NEEDLE TENSION SYSTEM

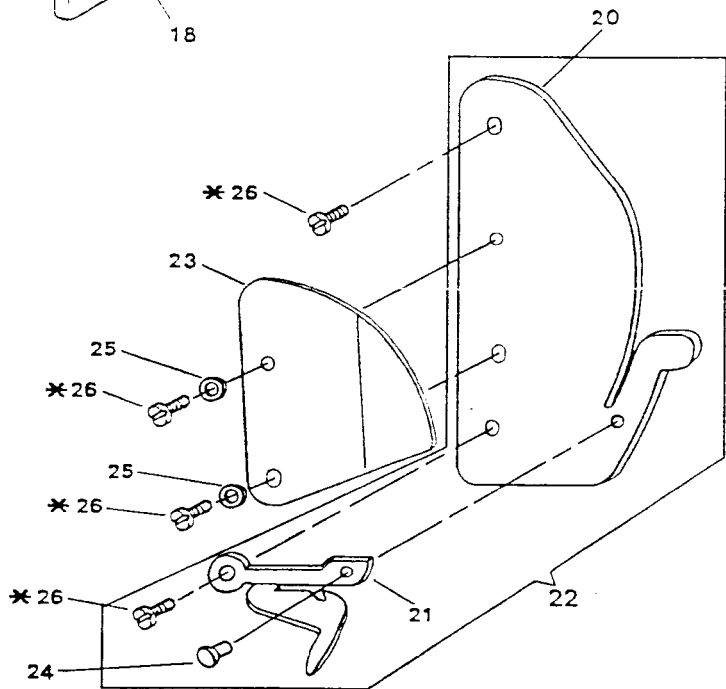
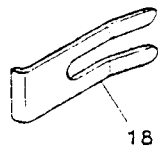
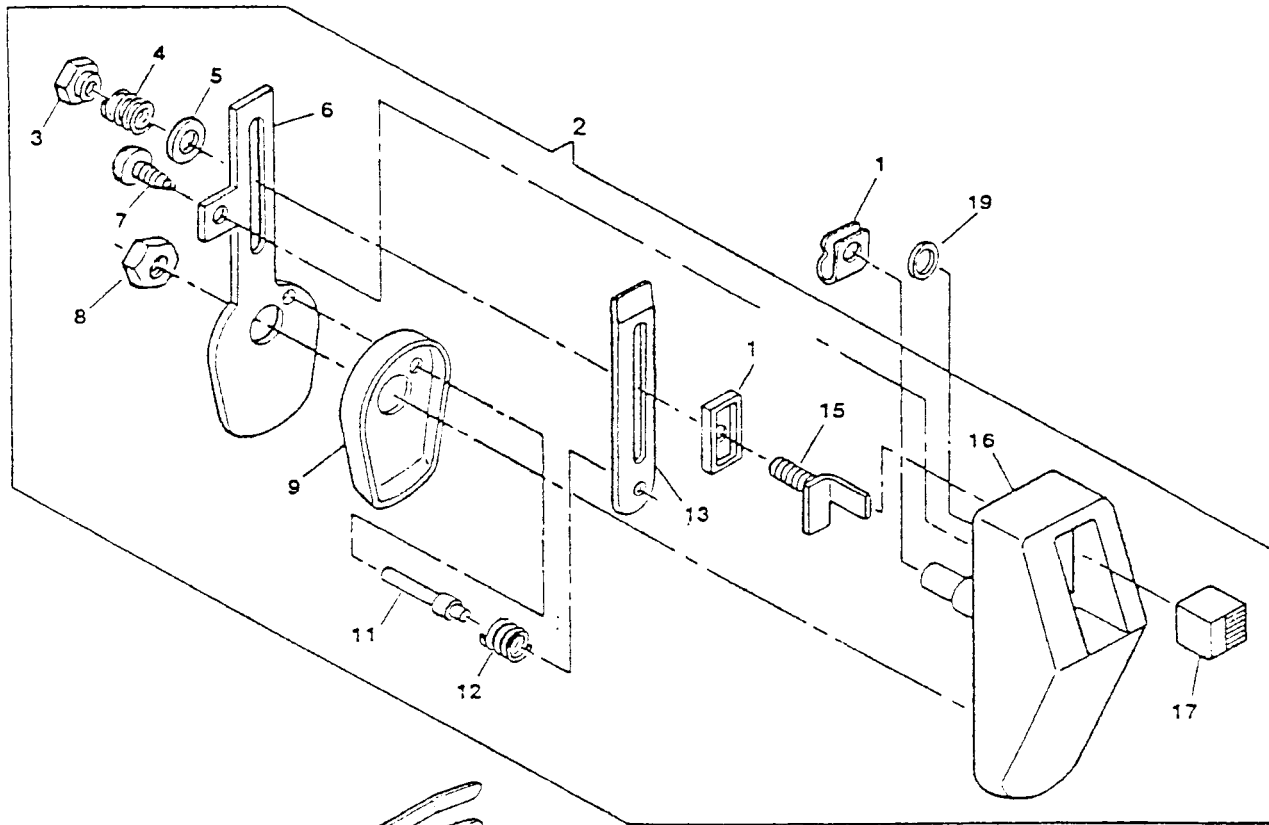

# ELECTRICAL EQUIPMENT

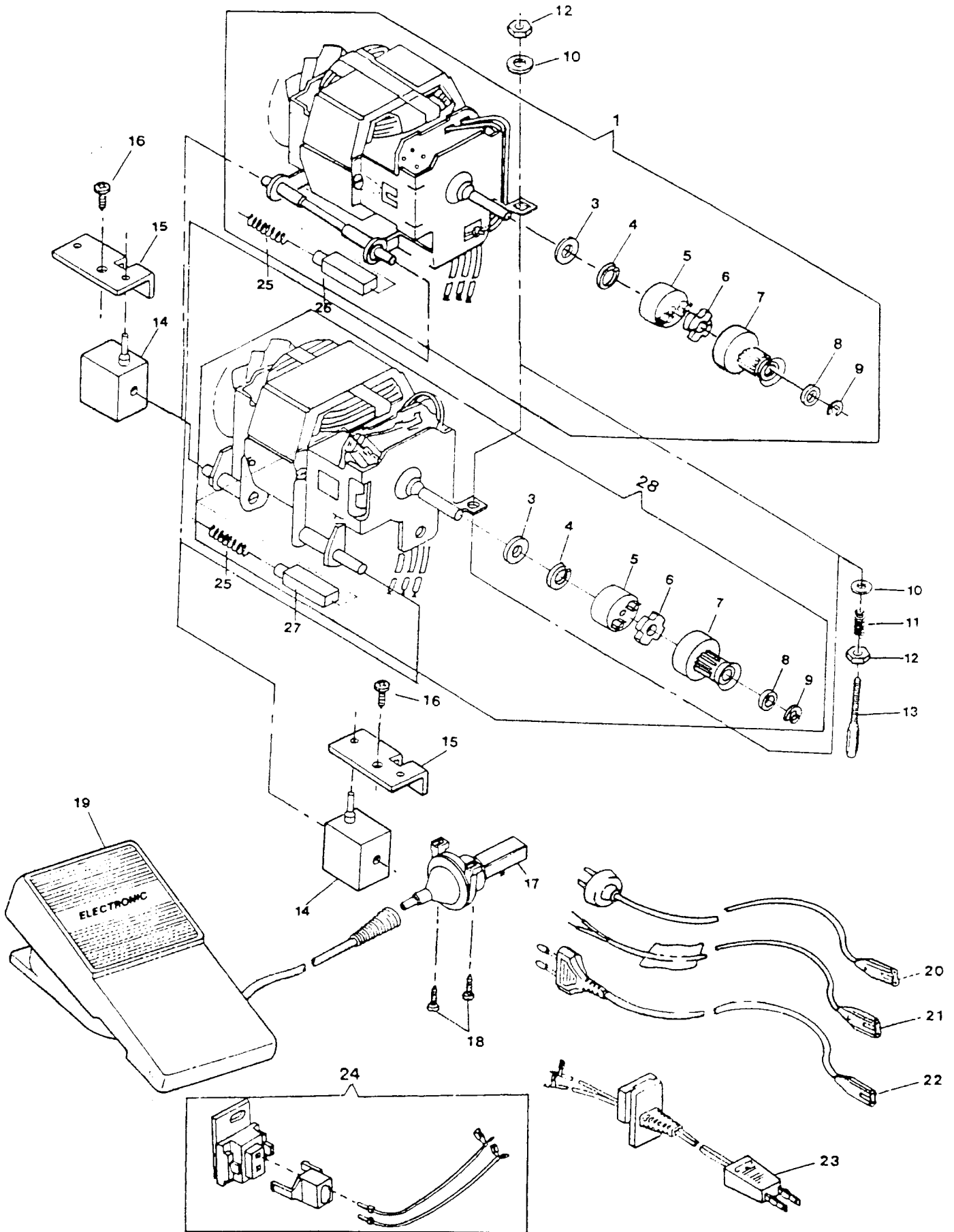

From the library of: Diamond Needle Corp



ELECTRICAL EQUIPMENT  
MODEL:9410

REF. PART NO.	PART NO.	DESCRIPTION
1	988529-009	MOTOR COMP. (CAT. NO. TA4-8) 120 VOLT (NATIONAL MOTOR)
1	988529-010	MOTOR COMP. (CAT. NO. TA4-11) 220/240 VOLT (NATIONAL MOTOR)
3	931744-001	SPACER WASHER (AS REQUIRED)
3	931744-002	SPACER WASHER (AS REQUIRED)
3	931744-003	SPACER WASHER (AS REQUIRED)
3	931744-103	SPACER WASHER (AS REQUIRED)
4	603908-001	RETAINING RING
5	988738-002	MOTOR PULLEY ISOLATOR HUB
6	988795-001	MOTOR PULLEY TORQUE CUSHION
7	979124-001	PULLEY WITH BELT RETAINER
8	988717-001	WASHER
9	619279-902	MOTOR PULLEY ISOLATOR HUB RETAINING RING
10	37969	MOTOR ADJUSTING STUD NUT WASHER
11	314058	MOTOR BELT TENSION SPRING
12	53646	MOTOR ADJUSTING STUD NUT
13	988653-001	MOTOR ADJUSTING STUD
14	979329-001	RESILIENT MOUNT
15	988651-001	CLIP
16	113470-004	MOTOR MOUNTING SCREW
17	988549-005	PNEUMATIC TRANSDUCER
18	113444-003	PNEUMATIC TRANSDUCER MOUNTING SCREW
19	988667-001	PNEUMATIC CONTROLLER ASSEMBLY
20	988638-004	APPLIANCE COUPLER FOR AUSTRALIA (BICENTENNIAL)
21	988638-003	APPLIANCE COUPLER (240 VOLT) FOR U.K.
22	988638-001	APPLIANCE COUPLER (220 VOLT) FOR EUROPE
23	988557-001	CORD W/STRAIN RELIEF AND PLUG (120 VOLT) FOR U.S./CANADA
24	988657-003	CORD WITH RECEPTACLE (EUROPE/U.K./AUSTRALIA/JAPAN)
25	619436-001	BRUSH SPRING (2)
26	619435-013	MOTOR BRUSH (2) (FOR NATIONAL MOTOR)
27	619435-015	MOTOR BRUSH (2) (FOR ITU MOTOR)
28	988529-009	MOTOR COMP. (CAT. NO. TA4-8) 120 VOLT (ITU MOTOR)
28	988529-010	MOTOR COMP. (CAT. NO. TA4-11) 220/240 VOLT (ITU MOTOR)

ELECTRICAL EQUIPMENT (CONT.)  
MODEL:9410

REF. PART NO. NO.	DESCRIPTION
1 314596-001	LINT AND HEAT SHIELD ASSEMBLY (220/240V)
2 979203-002	LIGHT ASSEMBLY (EUROPE) (220V)
2 979203-003	LIGHT ASSEMBLY (AUSTRALIA) (240V) (BICENTENNIAL)
3 540899	TY-WRAP SELF-LOCKING (ALT: 605600-001)
4 979203-001	LAMP SOCKET (120V) (US/CANADA)
5 314596-002	LINT AND HEAT SHIELD ASSEMBLY (100V)
5 314596-003	LINT AND HEAT SHIELD ASSEMBLY (120V)
6 446138	HEAT SHIELD MOUNTING SCREW WASHER
7 544211-002	HEAT SHIELD MOUNTING SCREW
8 194120-021	LIGHT BULB (240 VOLT) (ALT: 542656-004) (BICENTENNIAL)
8 194120-020	LIGHT BULB (220 VOLT) (ALT: 542656-003)
8 194120-019	LIGHT BULB (120 VOLT) (ALT: 542656-005)
9 113445-003	THREAD TAKE-UP COVER AND LINT/HEAT SHIELD SCREW
10 988547-002	WASHER
11 113444-001	SCREW (P. C. BOARD MOUNTING)
12 988548-007	SWITCH OPERATOR (120 VOLT)
13 988547-001	WASHER
14 979123-004	SPEED CONTROL P. C. BOARD ASSEMBLY 120 VOLT (FULL WAVE)
14 979120-005	SPEED CONTROL P. C. BOARD ASSEMBLY 220/240 VOLTS (FULL WAVE)
14 979192-005	SPEED CONTROL P. C. BOARD ASSEMBLY 220/240 VOLTS (FULL WAVE)
14 979161-003	SPEED CONTROL P. C. BOARD ASSEMBLY 100 VOLT (FULL WAVE)
15 113455-001	SCREW (LIGHT HARNESS)
16 604690-001	SELF-LOCKING NYLON CABLE TIE (LIGHT HARNESS)

### ELECTRICAL EQUIPMENT (CONT.)

